



AIRENG INDUSTRIAL & COMMERCIAL FANS

10 Turbo Drive
Bayswater Vic 3153
Tel: (03) 9738 1999
Fax: (03) 9738 1766
E-mail: fans@aireng.com.au

Rubber Mountings - RMA series Data Sheet

Application

- Where effective isolation of noise and vibration from equipment with speeds of 1,000 RPM upwards is required at a low cost.

Options

- Available in alternative elastomers (special order)

Features

- Static deflection of 5 - 12mm
- Top insert threaded
- Ribbed, non-skid base
- Load ranges colour-coded
- Resistant to corrosion

Construction

Material: Black filled natural rubber; Ozone and UV inhibited. Corrosion protected metal parts embedded in elastomer.

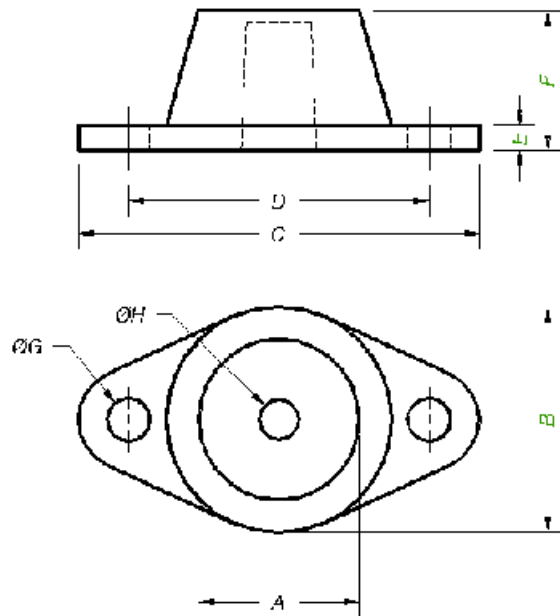

Part No.	Colour	Max. Load (kg)	Static Deflection (mm)	A (mm)	B (mm)	C (mm)	D (mm)	E (mm)	F (mm)	Dia. G (mm)	Dia. H Thread
RMA1-01 -02 -03 -04	Blue White Green Yellow	15 25 40 60	5	32	45	80	60	5	28	8.5	M8
RMA2-01 -02 -03 -04	Blue White Green Yellow	15 25 40 60	10	32	45	80	60	5	35	8.5	M8
RMA3-01 -02 -03 -04	Blue White Green Yellow	60 75 110 175	6	45	60	98	76	6	32	8.5	M10
RMA4-01 -02 -03 -04	Blue White Green Yellow	60 75 110 175	12	45	60	98	76	6	44	8.5	M10
RMA5-01 -02 -03 -04	White Green Yellow Red	115 240 340 500	6	64	85	140	104	6	44	14	M12
RMA6-01 -02 -03 -04	White Green Yellow Red	115 240 340 500	12	64	85	140	104	6	72	14	M12
RMA7-01 -02 -03 -04	White Green Yellow Red	680 1020 1360 1800	12	100	110	165	127	6	75	14	M12
RMA8-01 -02 -03 -04	White Green Yellow Red	680 1020 1360 1800	6	100	110	165	127	6	45	14	M12